

KIT GUARDIAN TELESCOPIC CANTILEVER GATE SYSTEM

Descrizione

This kit is made of galvanized steel ideal for installation on cantilever gates. A stainless steel wire is used to transfer the telescopic motion. The leaves moves simultaneously and have the advantage of taking less space compared to a single ground track cantilever gate when the gate is in the open position. This feature makes the product ideal for sites where space is limited. Note: To correctly install this kit add the following technical sheets:

- KA5102 Multi-leaf telescopic gate
- KD2100 Guardian Cantilever

Family of parts

KD2150

Versione DX/Right version

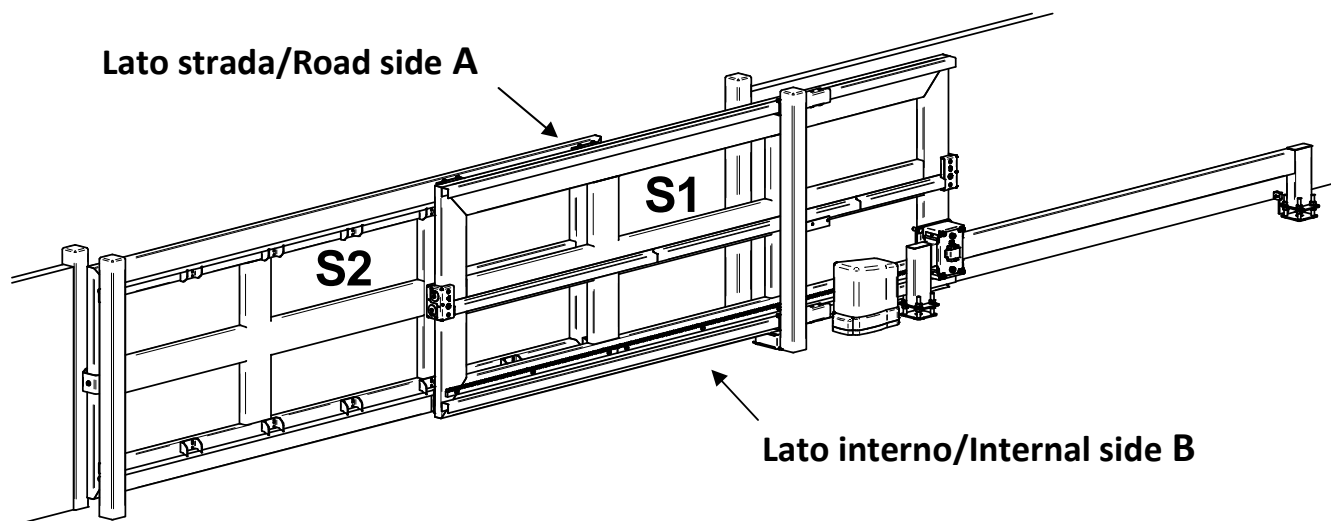

Elenco parti/Component list

1xKA5102.006	1xKD3100.075	1xVD2100.100	1xVD2200.100	2xVD2500.100
1	2	3	4	5
2xVD2501.100	VA5401.003/006 Optional	VA5411.001 Optional	VA5312.001 Optional	Articoli Colplementari Complementary articles
6	7	8	9	

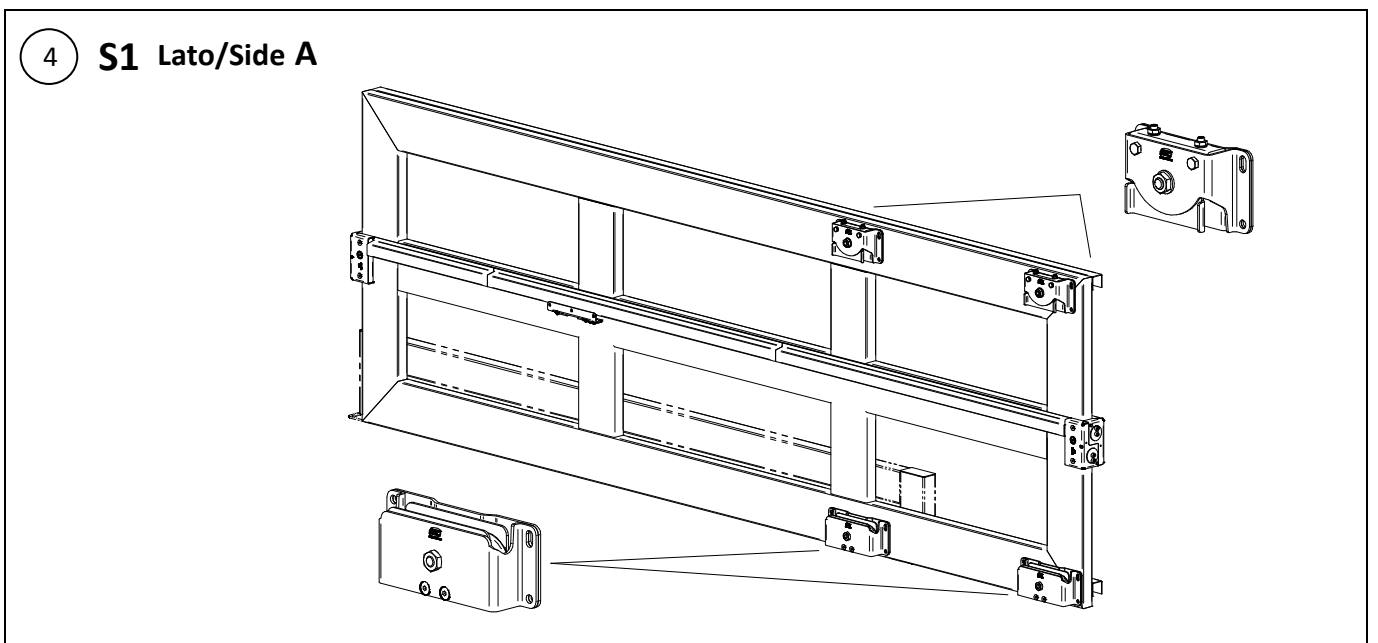
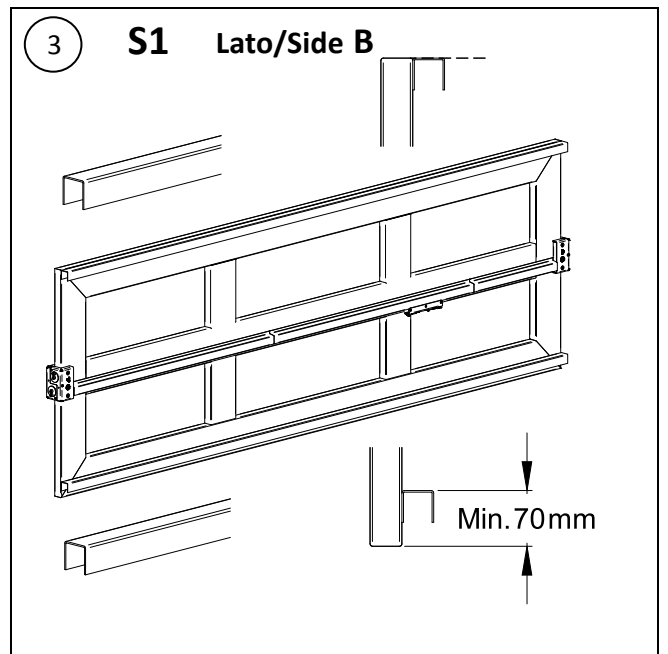
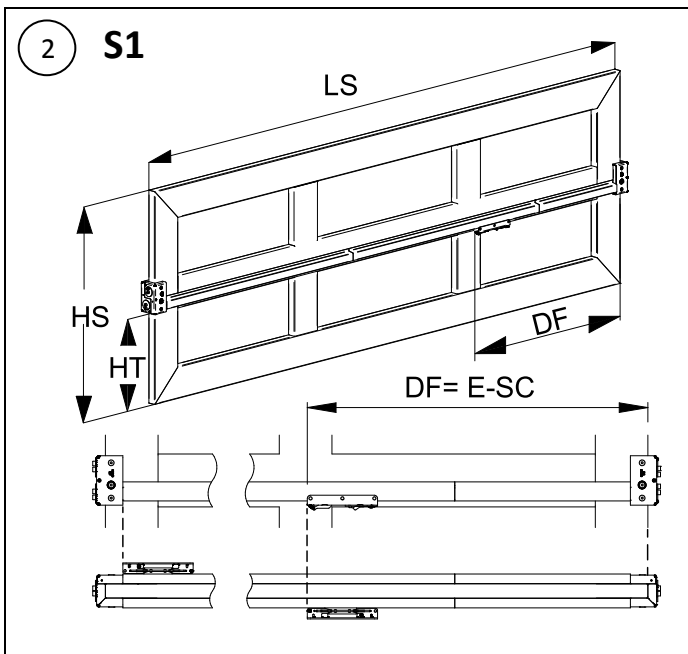
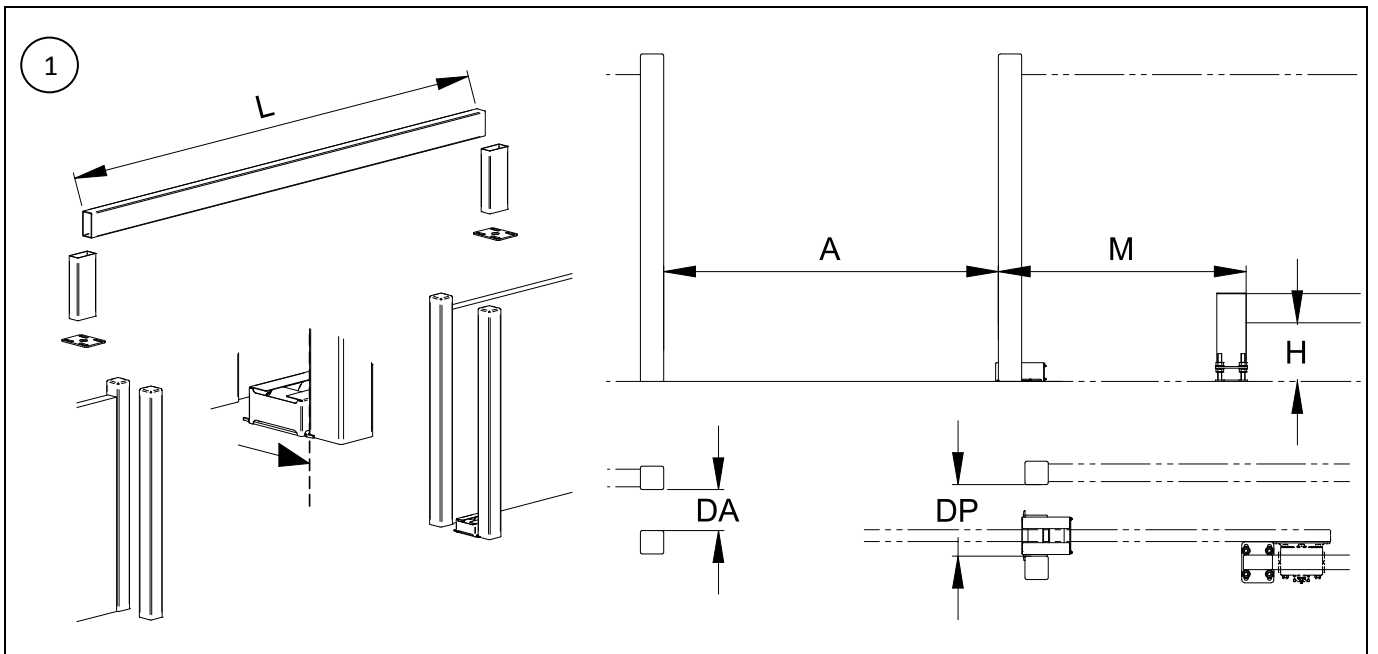

Attention: installations that do not comply with the illustrated procedure or failure to carry out correct maintenance operations can cause the gate to derail and endanger the safety of persons and property

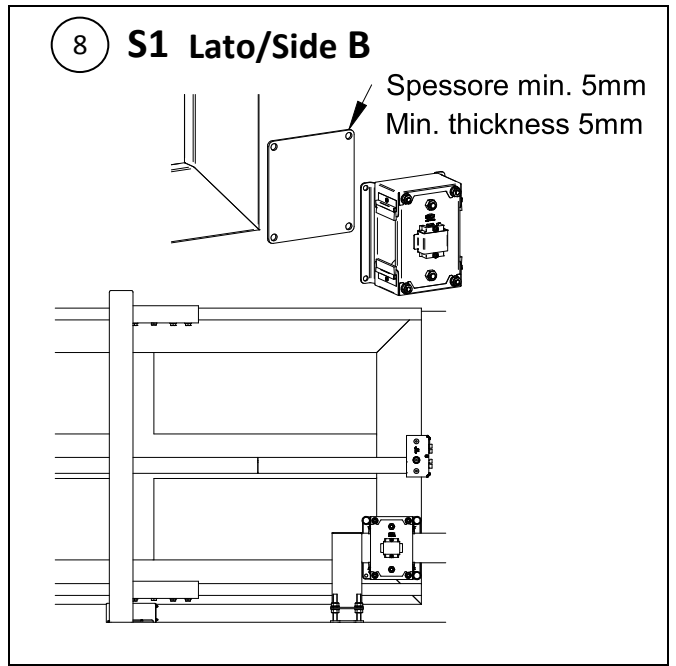
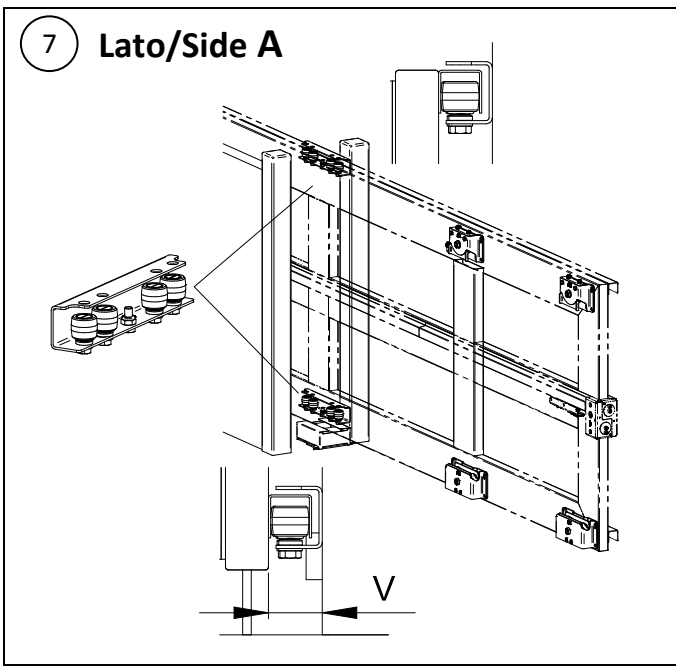
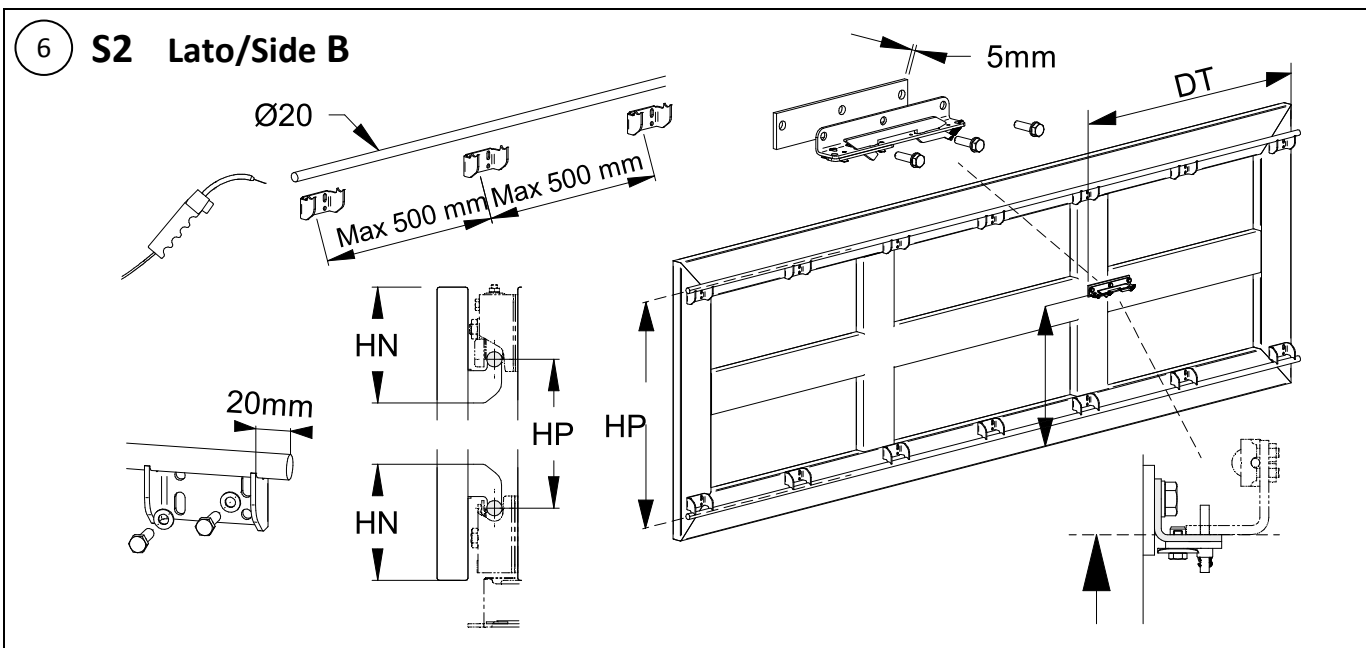
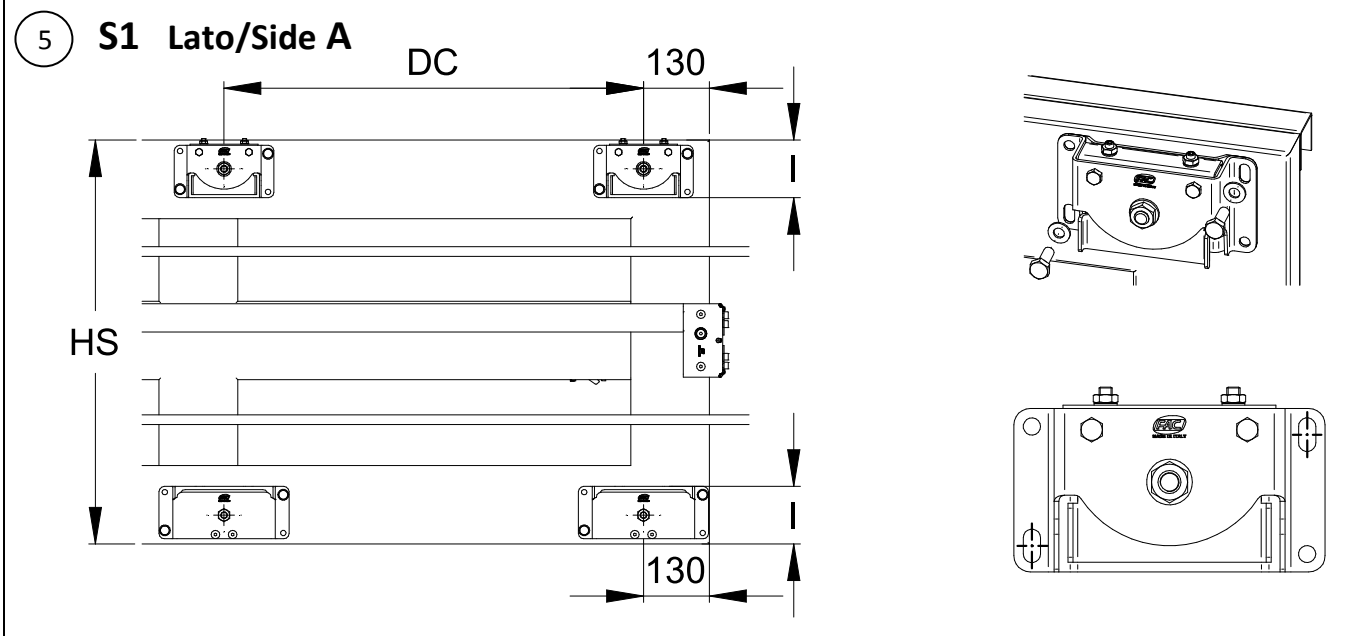

Attention: installations that do not comply with the illustrated procedure or failure to carry out correct maintenance operations can cause the gate to derail and endanger the safety of persons and property

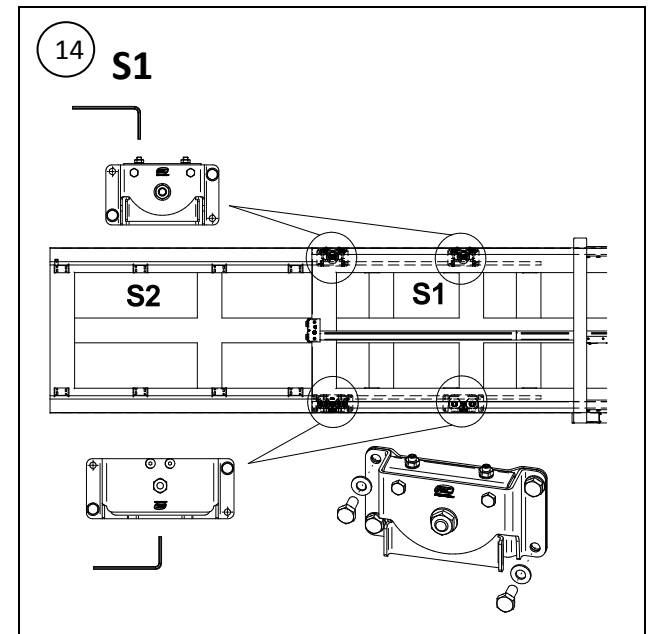
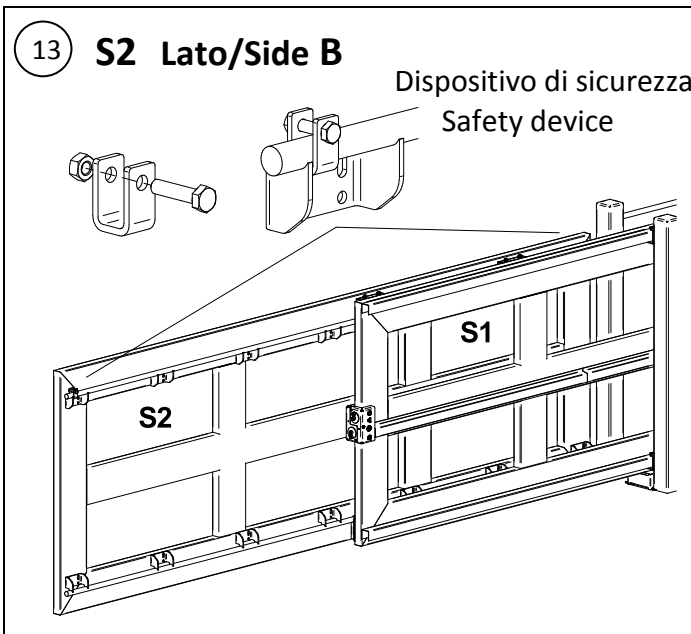
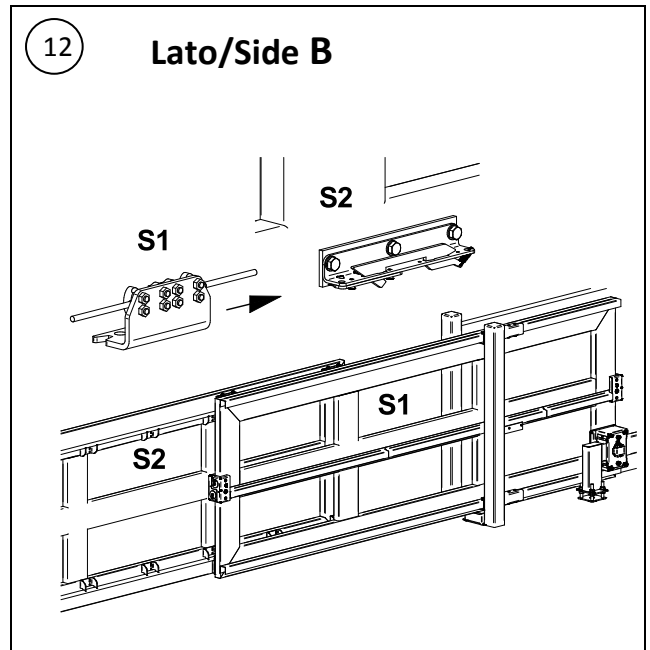
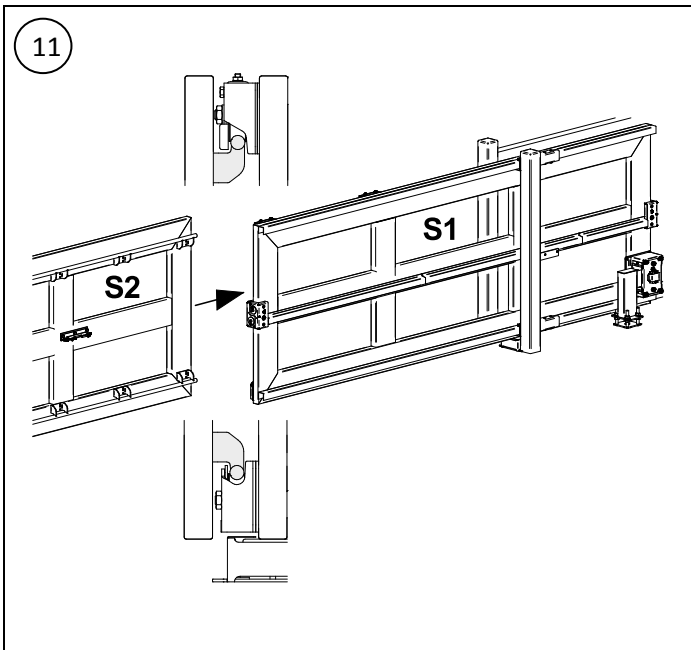
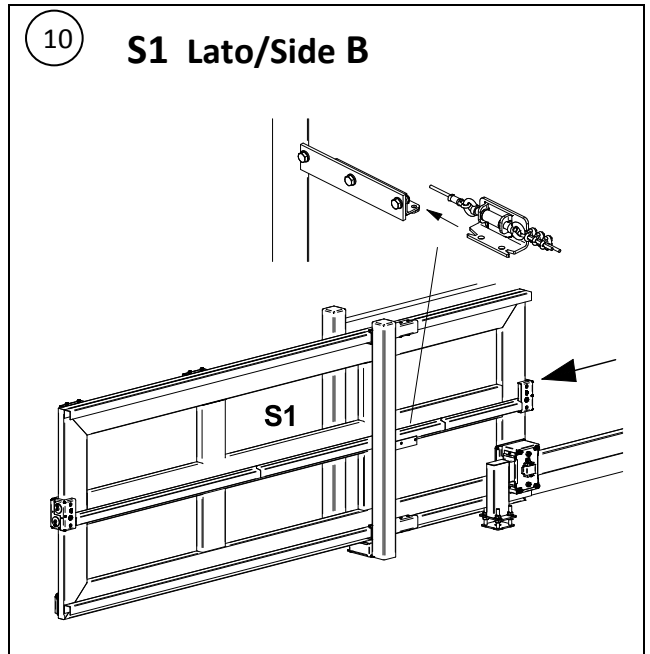
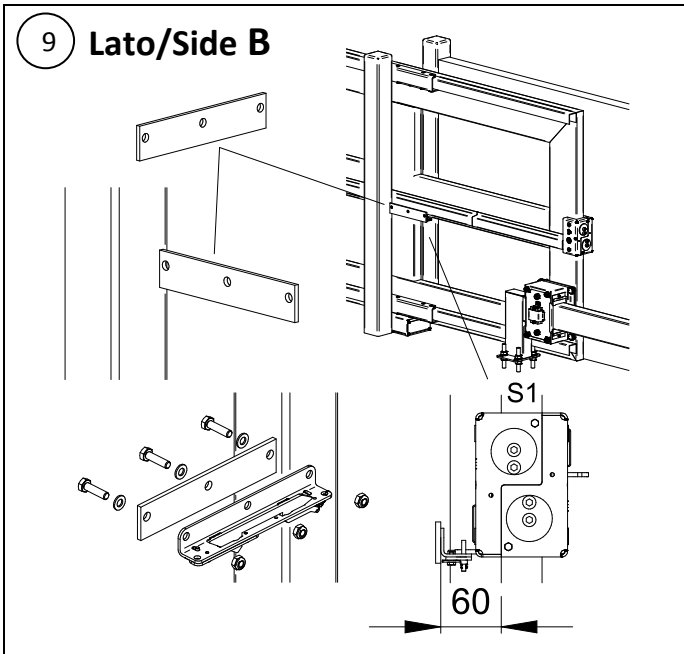

Attention: installations that do not comply with the illustrated procedure or failure to carry out correct maintenance operations can cause the gate to derail and endanger the safety of persons and property

15 S2 Lato/Side B

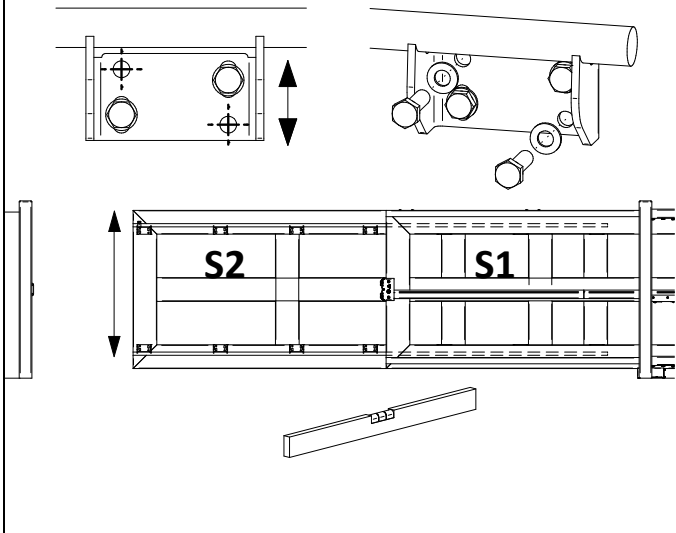

16 S1 Lato/Side B

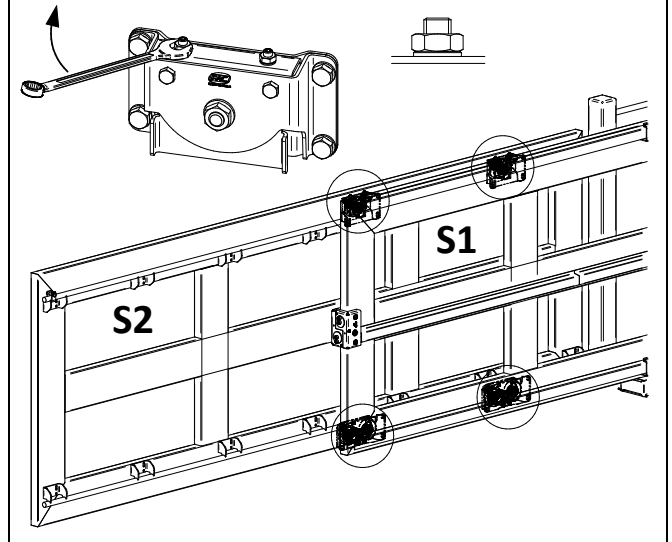

17

Vista lato strada/Road side View A

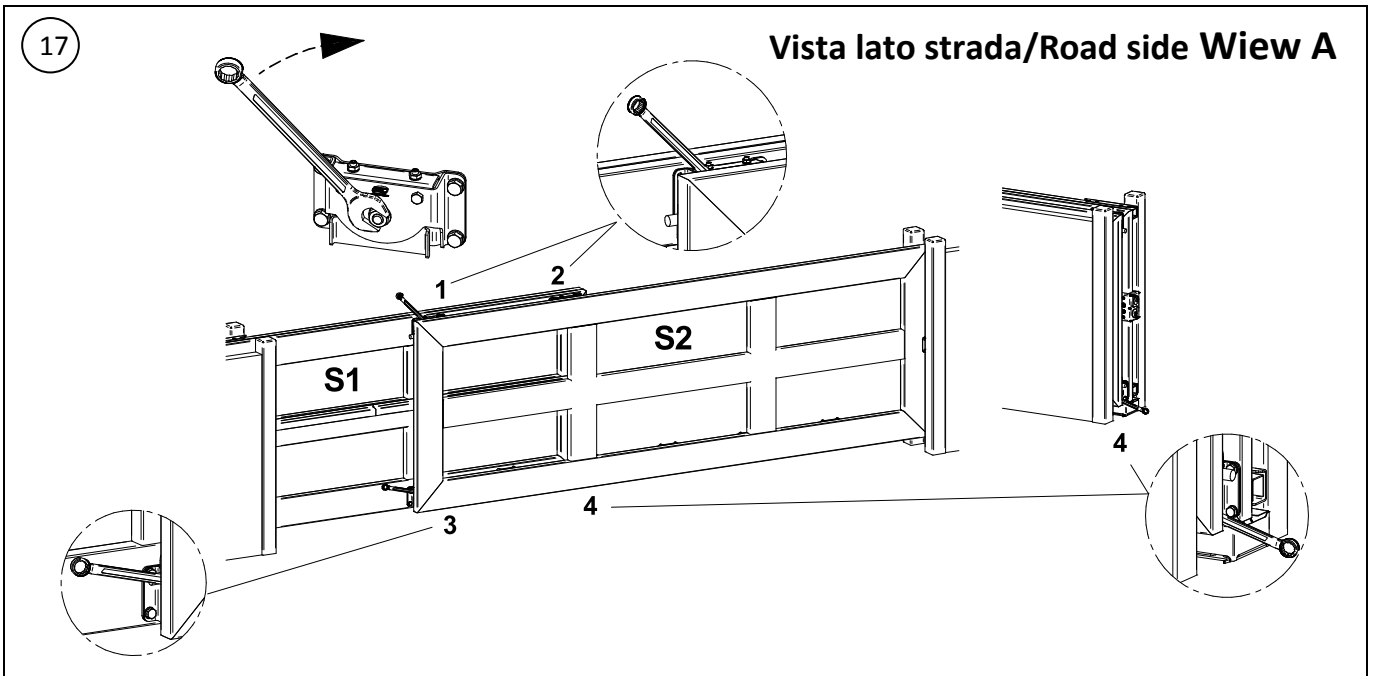

19 S1 Carter optional per tubolari > 40 mm / Optional Carter for tubular > 40mm

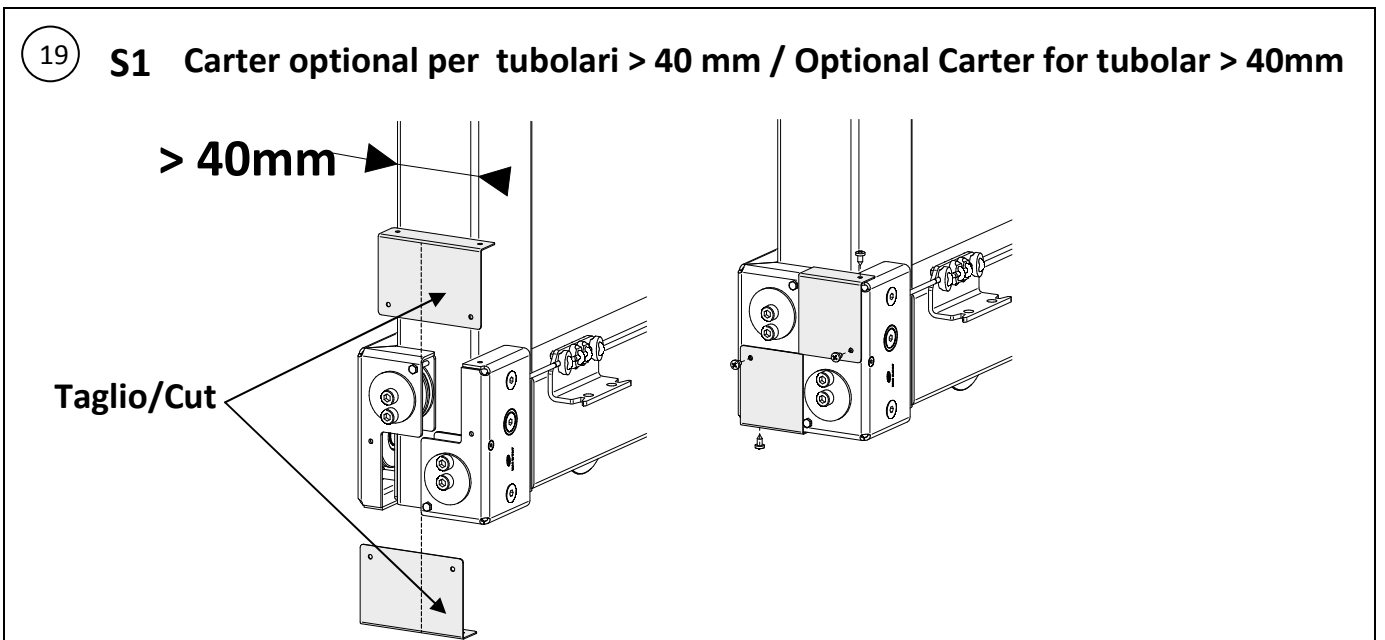

Attention: installations that do not comply with the illustrated procedure or failure to carry out correct maintenance operations can cause the gate to derail and endanger the safety of persons and property

Versione Sinistra/Left version

Stesse istruzioni ma da interpretare in senso opposto/ Same instructions but to be interpreted in the opposite direction
Attenzione soprattutto ai punti sotto indicati/ Pay attention to the points listed below

- Rimontare tutti i kit aggancio nel verso opposto/ Install all the kit coupling in the opposite direction

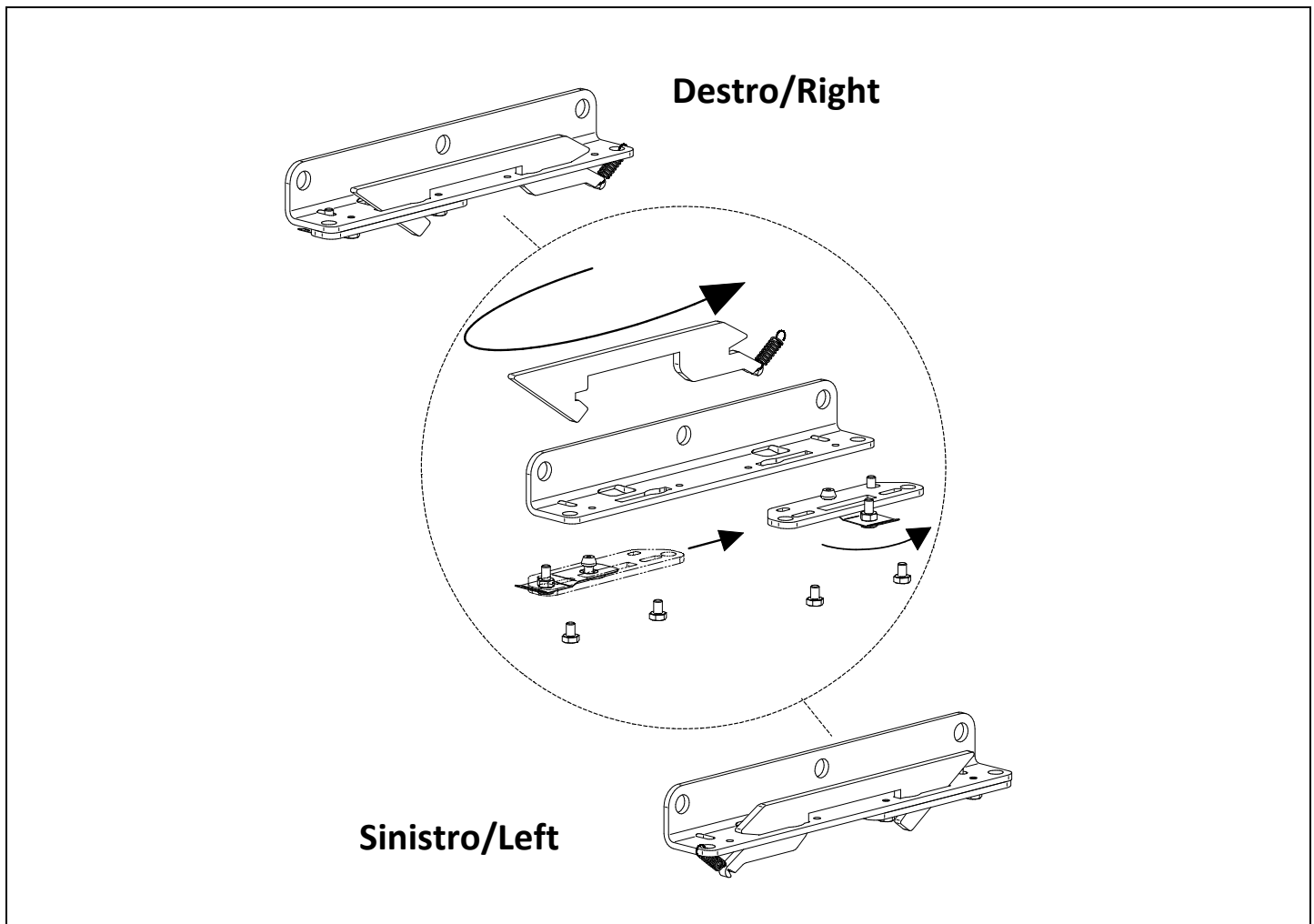
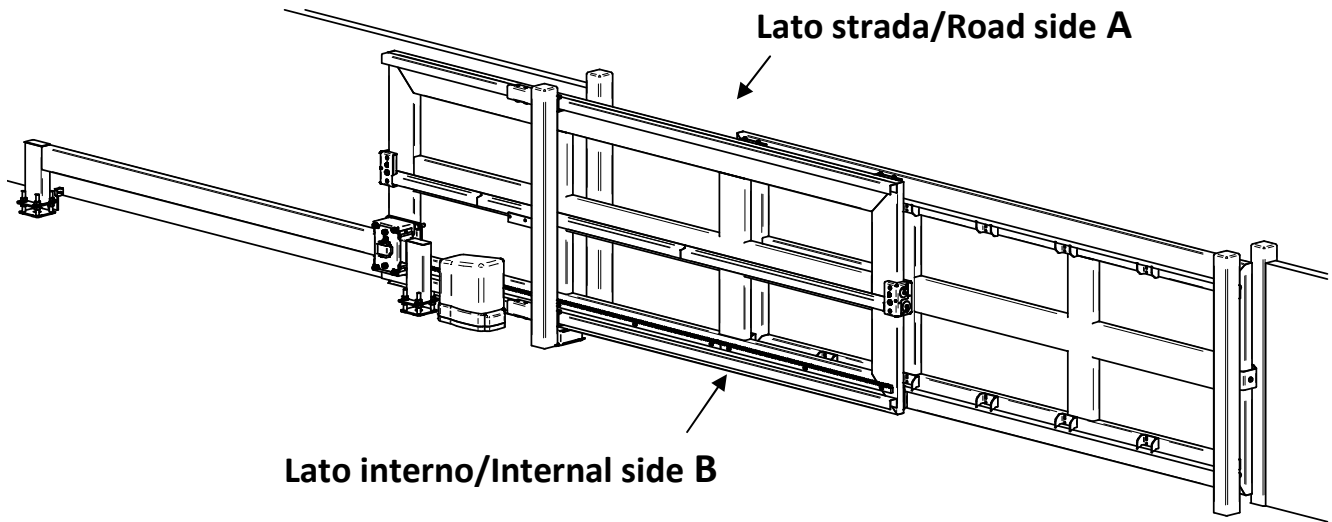

Attention: installations that do not comply with the illustrated procedure or failure to carry out correct maintenance operations can cause the gate to derail and endanger the safety of persons and property

TABELLA DIMENSIONAMENTO - DIMENSIONING TABLE

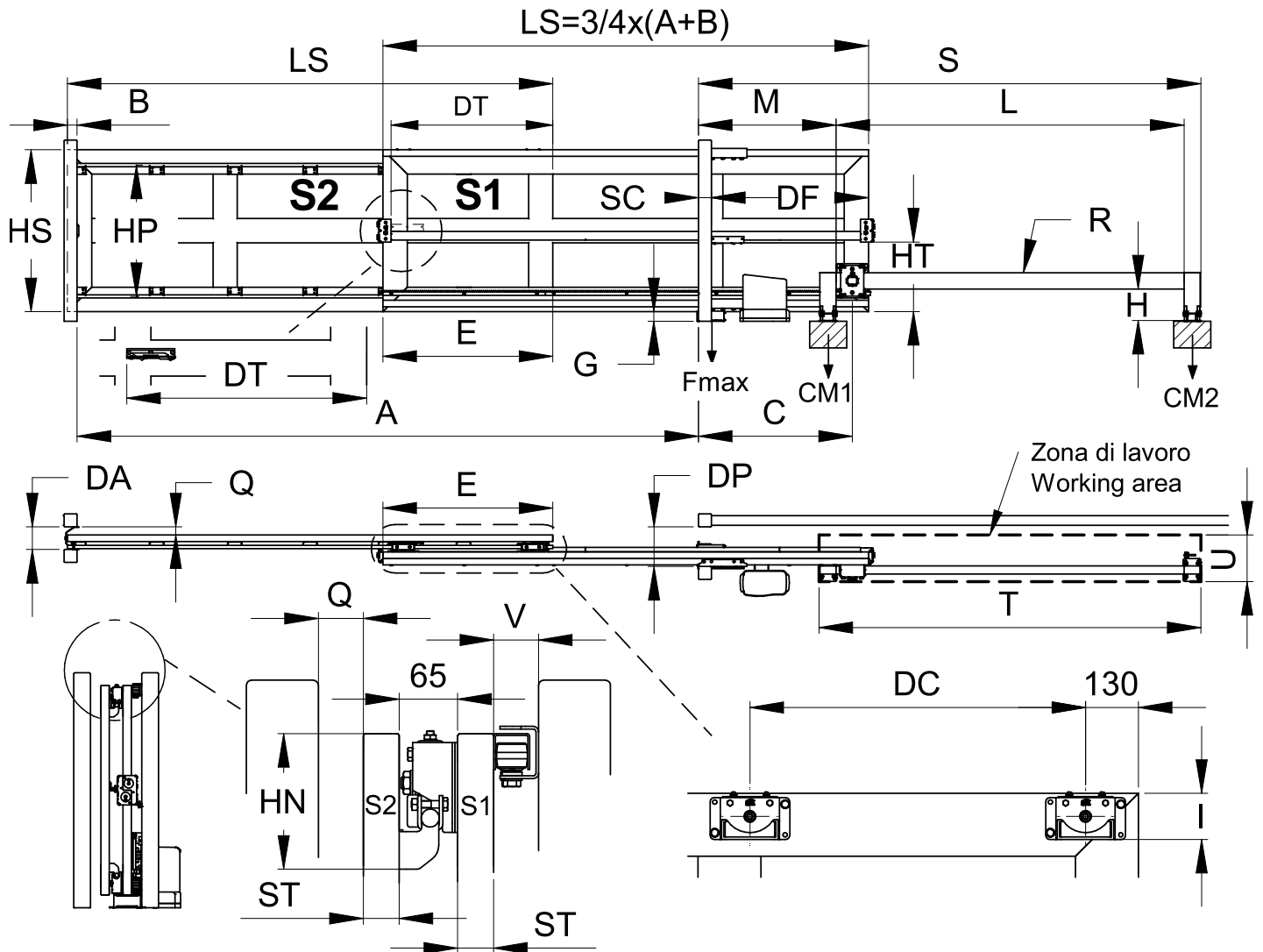

KD2150.100 A min 3,5m – max 8m

S1+S2 Max 500 Kg

Gmin [m]	Hmin [m]	Vmin [mm]	HS min [m]	HN min [mm]	HT min [m]	I min [mm]	R [mm]	ST [mm]	Fmax [kg]	S2 max[kg]	S1+S2 max[kg]	CM1min [kg]	CM2min [kg]	U [m]
0,06	0,200	50	0,6	140	0,300	100	100x50 sp.3	40÷80	950	250	500	1000	100	0,29÷0,37

LS (m) and correlated C-M-S value given in table are calculates with B=0,08m

With a different B value update the end value by adding or subtracting the B value difference

A [m]	LS [m]	E [m]	C [m]	DC [m]	Smin [m]	L [m]	M [m]	T [m]	Q [mm]	DT [m]
3,5	2,69	0,9	0,8	0,64	~2,89	2,01	0,7	2,29	50	0,85
4	3,06	1,02	0,93	0,76	~3,26	2,32	0,83	2,60	50	0,97
4,5	3,44	1,15	1,05	0,89	~3,64	2,52	0,95	2,80	50	0,11
5	3,81	1,27	1,18	1,01	~4,01	2,83	1,08	3,11	50	1,22
5,5	4,19	1,40	1,3	1,14	~4,39	3,22	1,2	3,39	50	1,35
6	4,56	1,52	1,43	1,26	~4,76	3,26	1,33	3,54	60	1,47
6,5	4,94	1,65	1,55	1,39	~5,14	3,60	1,45	3,88	60	1,60
7	5,31	1,77	1,68	1,51	~5,51	3,72	1,58	4,00	60	1,72
7,5	5,69	1,90	1,80	1,64	~5,89	3,97	1,7	4,25	60	1,85
8	6,06	2,02	1,93	1,76	~6,26	4,22	1,83	4,50	60	1,97



Attention: installations that do not comply with the illustred procedure or or failure to carry out correct maintenance operations can cause the gate to derail and endanger the safety of persons and propriety

Esempio calcolo lunghezza anta LS x misure fuori tabella ***Example leaf calculation length LS x measures not in table***

$$A=4,2\text{mt}$$

$$B=0,1\text{mt}$$

$$LS=3/4 \times (A+B)$$

$$LS=3/4 \times (4,2+0,1)=3,225\text{mt}$$

Altre formule utili ***Other useful formulas***

$$E[\text{m}] = LS/3$$

$$L[\text{m}] = 1/2(A+B)+0,22$$

$$M[\text{m}] = C-0,1$$

$$T[\text{m}] = L+0,28$$

$$S[\text{m}] = LS+0,2$$

$$C[\text{m}] = E-0,1$$

$$DA[\text{mm}] = Q+ST+60$$

$$DP[\text{mm}] = (2 \times ST)+V+Q+65$$

$$HP[\text{mm}] = HS-(2 \times l)+30$$

$$DC[\text{m}] = E-0,26$$

$$DT[\text{m}] = E-0,05$$

$$DF = E-SC$$

Maintenance

To maintain these parts in good and safe working conditions it is necessary to follow these steps:

1. After gate assembly is completed, perform a few manual opening and closing cycles, make sure there are no loose parts and periodically lubricate all the system.
2. In case of accidental shock caused by moving vehicles or other external factors, check parts for external damages. In case of irreparable damage, replace with a new part. Always check the gate by manually opening a few opening opening and closing cycles. All maintenance procedures must be performed by trained technicians.
3. If the gate has any difficulty of movement or in presence of abnormal oscillations, the gate must be checked for worn parts replaced if necessary. Gates working in harsh ambient conditions, such as; high humidity, salt, acids, dust or temperatures above 120°C will require special attention and frequent maintenance.
4. For motorized gates, pay special attention when selecting the operational speed. Soft starts and stops are highly recommended:
 - High speed of operation, and hard starts and stops will be stressful to the system and it may result in loosen nuts, bolts and irreparable damage.
 - Low operational speeds may cause an elastic effect between the leaves



Attention: installations that do not comply with the illustrated procedure or failure to carry out correct maintenance operations can cause the gate to derail and endanger the safety of persons and property