

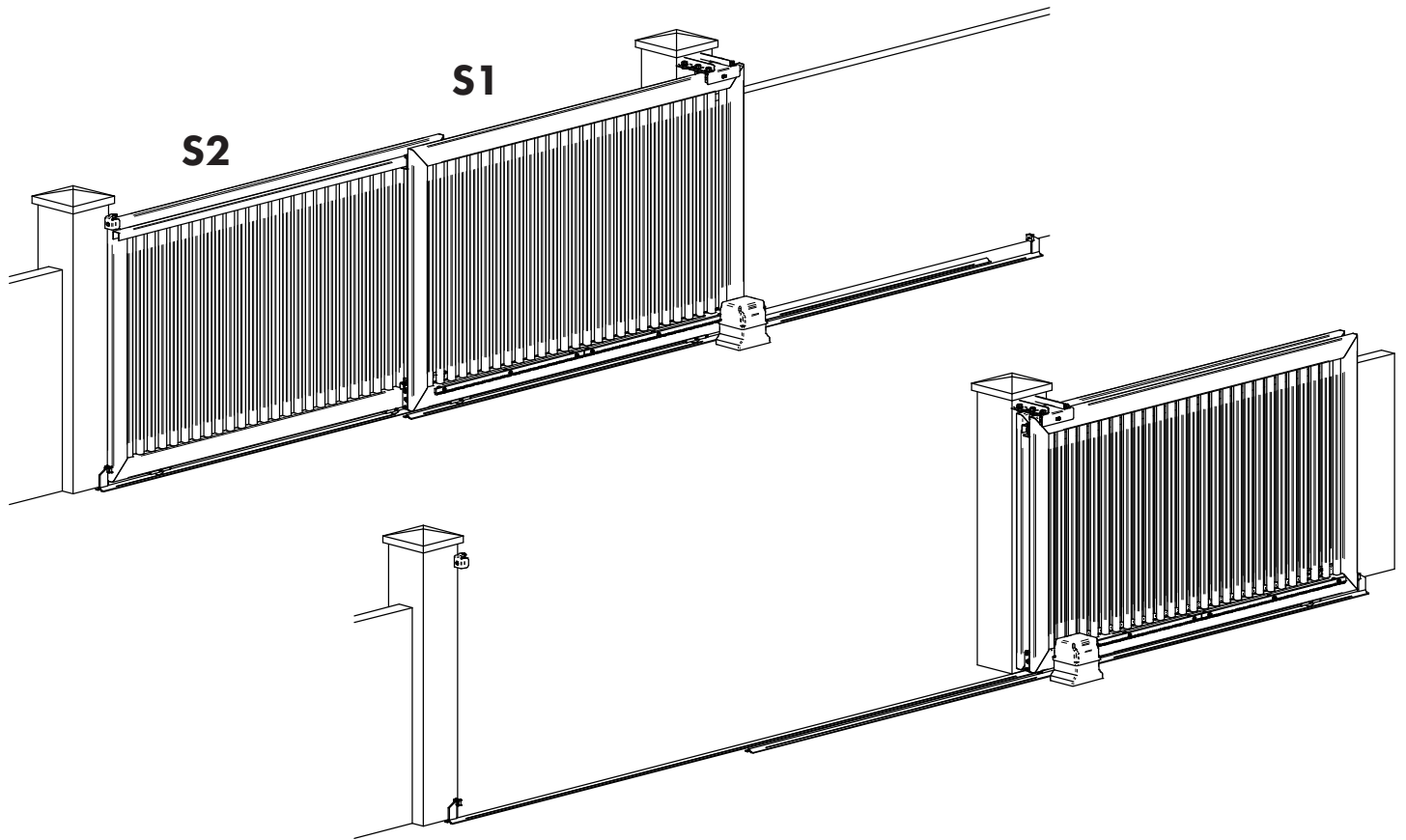

KIT PUERTA TELESCOPICA DE 2 HOJAS TWO-LEAVES TELESCOPIC KIT

Kit de accesorios cincados con cable de propileno para la fabricación de puertas telescópicas de 2 hojas.

Galvanized accessories kit with propylene cable for the construction of two leaves telescopic gates.



HASTA 4m DE APERTURA - OPENING UP TO 4m

KA5100.104	Ruedas D.90 canal V / D.90 V groove wheels	M
KA5100.404	Ruedas D.90 canal U de 20 / D.90 half-round groove wheels 20mm	M

HASTA 8m DE APERTURA - OPENING UP TO 8m

KA5100.108	Ruedas D.90 canal V / D.90 V groove wheels	M
KA5100.408	Ruedas D.90 canal U de 20 / D.90 half-round groove wheels 20mm	M

HASTA 11m DE APERTURA - OPENING UP TO 11m







KA5100.111	Ruedas D.100 canal V / D.100 V groove wheels	M
KA5100.411	Ruedas D.100 canal U de 20 / D.100 half-round groove wheels 20mm	M

HASTA 15m DE APERTURA - OPENING UP TO 15m

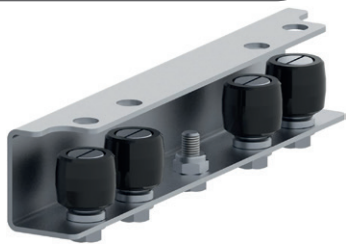
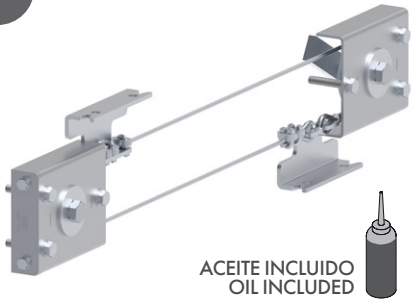
KA5100.115	Ruedas D.100 canal V / D.100 V groove wheels	M
KA5100.415	Ruedas D.100 canal U de 20 / D.100 half-round groove wheels 20mm	M

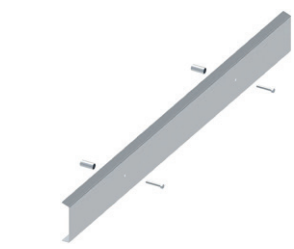

LISTA DE COMPONENTES
COMPONENTS

<p>x1</p> 	<table border="1"> <tr> <td>A max</td> <td>4m</td> <td>8m</td> <td>11m</td> <td>15m</td> </tr> <tr> <td>n° pz</td> <td>1</td> <td>1</td> <td>2</td> <td>2</td> </tr> </table> 	A max	4m	8m	11m	15m	n° pz	1	1	2	2	<p>x1</p>  <p>ACEITE INCLUIDO OIL INCLUDED</p>
A max	4m	8m	11m	15m								
n° pz	1	1	2	2								
<p>VA3501</p>	<p>VA3502</p>	<p>VA5101</p>										
<p>x1</p> 	<table border="1"> <tr> <td>A max</td> <td>4m</td> <td>8m</td> <td>11m</td> <td>15m</td> </tr> <tr> <td>n° pz</td> <td>2</td> <td>4</td> <td>6</td> <td>8</td> </tr> </table> 	A max	4m	8m	11m	15m	n° pz	2	4	6	8	<p>x3</p> 
A max	4m	8m	11m	15m								
n° pz	2	4	6	8								
<p>VA5201</p>	<p>VA5301</p>	<p>VA4101</p>										
<p>x4</p>  	<table border="1"> <tr> <td>A max</td> <td>4m</td> <td>8m</td> <td>11m</td> <td>15m</td> </tr> <tr> <td>n° pz</td> <td>6</td> <td>10</td> <td>13</td> <td>17</td> </tr> </table> 	A max	4m	8m	11m	15m	n° pz	6	10	13	17	
A max	4m	8m	11m	15m								
n° pz	6	10	13	17								
<p>VA1104</p>	<p>VA5411</p>											



ARTÍCULOS RELACIONADOS

Conéctese a nuestra pagina web para conocer los diferentes tipos y tamaños disponibles
RELATED ARTICLES

Click on our website for other related items

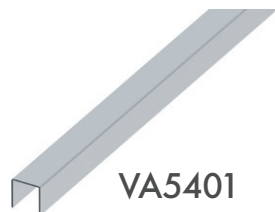

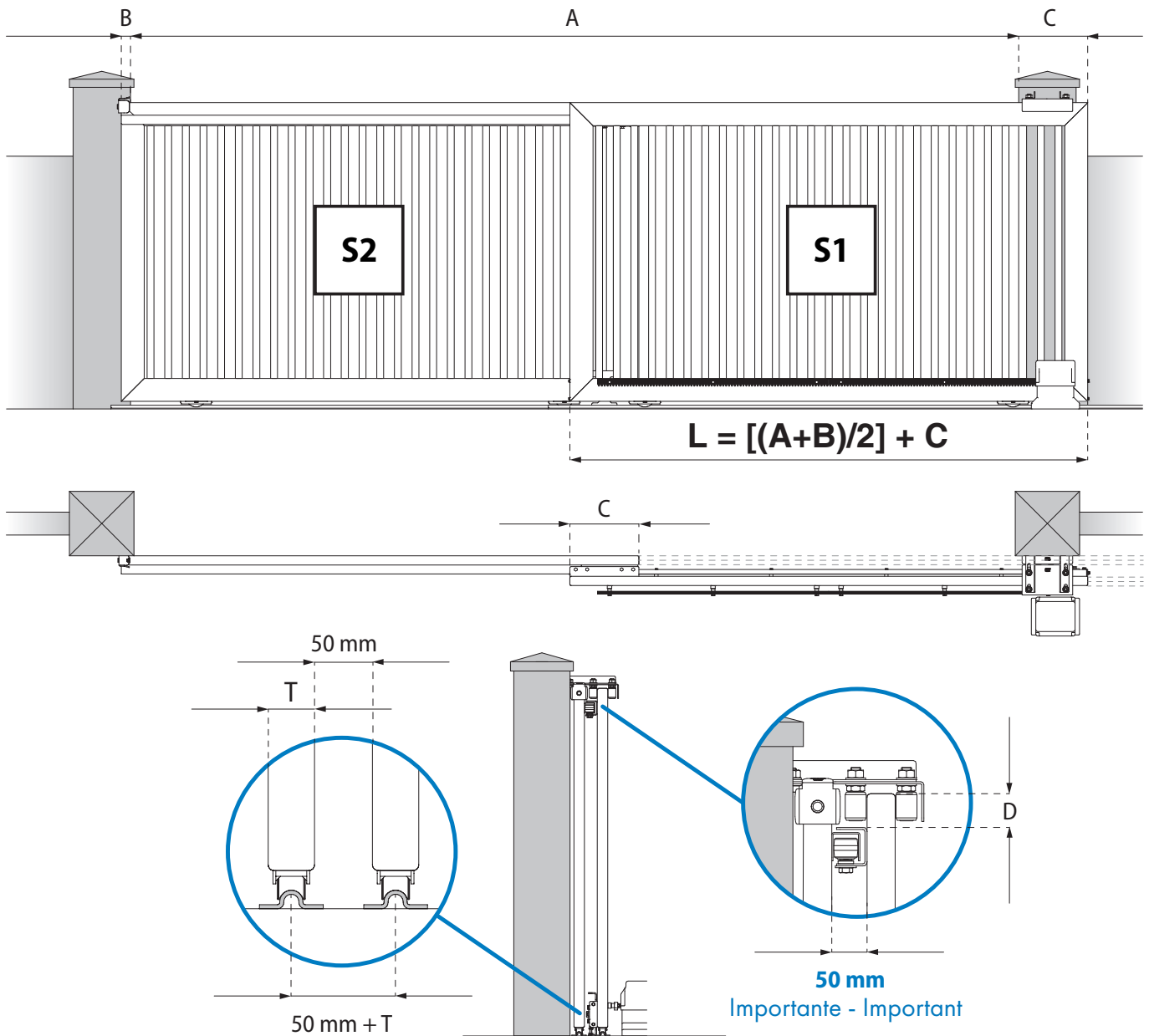

**TABLA DE DIMENSIONES
SIZE CHART**

CODIGO/ CODE	CANAL GROOVE	A max (m)	C (m)	D min (mm)	S2 max (kg)
KA5100.104	V	4	0,3	50	300
KA5100.404	U				
KA5100.108	V	8	0,3	50	300
KA5100.408	U				
KA5100.111	V	11	0,6	70	400
KA5100.411	U				
KA5100.115	V	15	0,6	70	400
KA5100.415	U				

**EJEMPLO DE MEDIDAS FUERA DE LA TABLA
EXAMPLE OF OUT-OF-TABLE MEASUREMENTS**

A = 3,5 m
 B = 0,06 m (seleccionado por el cliente / selected by the customer)
 C = 0,3 m (como en la tabla superior / as per above table)
 L = [(A+B)/2] + C
 L = [(3,5+0,06)/2] + 0,3
 L = [(3,56)/2] + 0,3
 L = 1,78 + 0,3
 L = 2,08

**DIMENSIONES DE LAS HOJAS
LEAVES DIMENSIONING**

CODIGO/ CODE	APERTURA OPENING (A)	L (m) con/with B=0,1 m
KA5100.104/ KA5100.404	3	1,85
KA5100.104/ KA5100.404	4	2,35
KA5100.108/ KA5100.408	5	2,85
KA5100.108/ KA5100.408	6	3,35
KA5100.108/ KA5100.408	7	3,85
KA5100.108/ KA5100.408	8	4,35
KA5100.111/ KA5100.411	9	5,15
KA5100.111/ KA5100.411	10	5,65
KA5100.111/ KA5100.411	11	6,15
KA5100.115/ KA5100.415	12	6,65
KA5100.115/ KA5100.415	13	7,15
KA5100.115/ KA5100.415	14	7,65
KA5100.115/ KA5100.415	15	8,15

Advertencia: La velocidad de la última hoja = doble velocidad que la motorizada
Warning: last leaf speed = motorized double speed.



INFORMACIÓN TÉCNICA
TECHNICAL INFO

1. Peso de referencia para la elección del motor = Peso S1 + (2x Peso S2).
2. Velocidad máxima S2 = 0,18m/s
3. Las Aceleraciones, deceleraciones y variaciones de alta velocidad pueden reducir la duración del sistema y causar funcionamientos defectuosos y roturas.
4. Variaciones sustanciales de la velocidad pueden causar efectos elásticos entre las hojas.
5. La instalación de los tornillos de seguridad y los topes es obligatoria.
6. Tensión óptima del cable: La suficiente para mantener el cable en posición horizontal. Una tensión inferior o superior pueden reducir su duración.
7. Motor recomendado: 24 voltios DC

1. Reference weight for the choice of the motor = Weight S1 + (2x weight S2)
2. S2 maximum speed = 0,18m/s
3. Accelerations, decelerations and high-speed variations can shorten the system duration and can cause malfunctions and disruptions.
4. Substantial variations in speed can cause elastic effects between the leaves.
5. The installation of security screws and limit stops is compulsory.
6. Cable optimum tension: enough to keep the cable in horizontal position. A lower or higher tension of the cable can shorten its duration.
7. Recommended motor: 24-volt DC

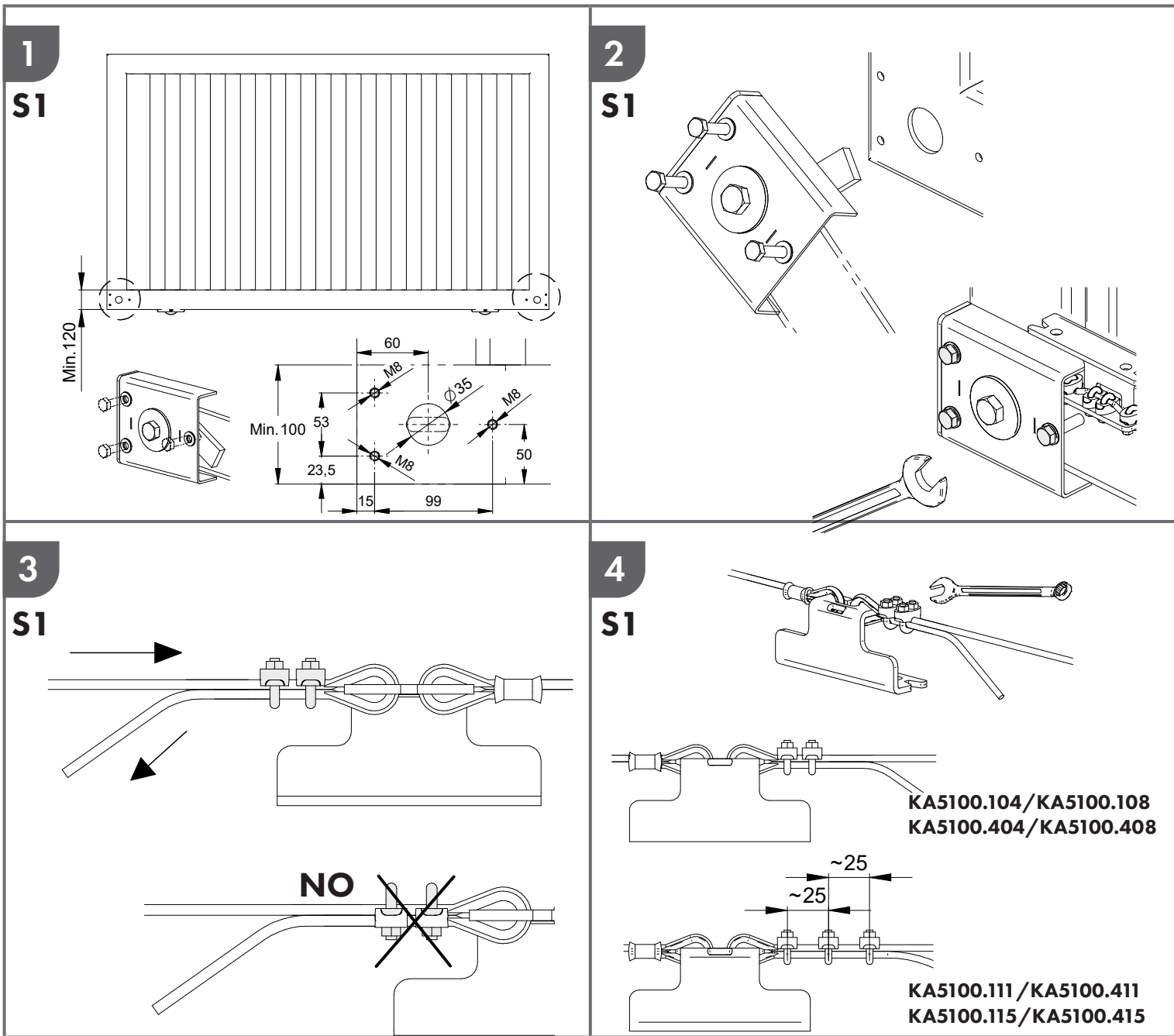



5

S1

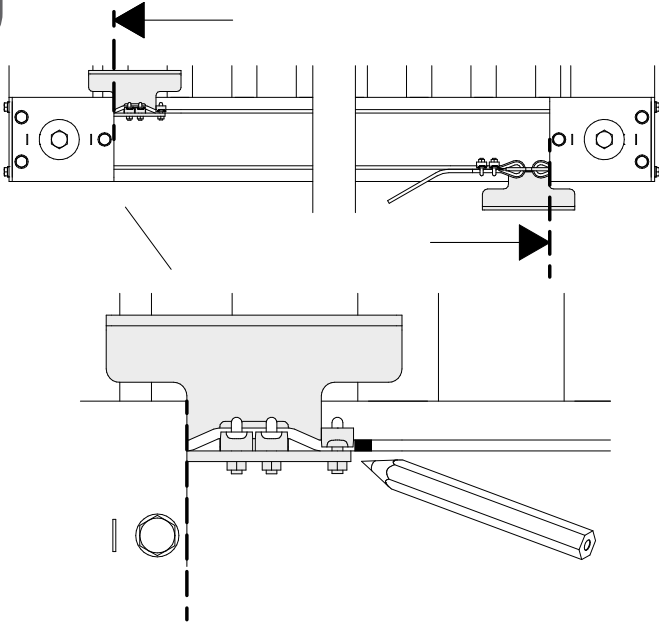

6

S1

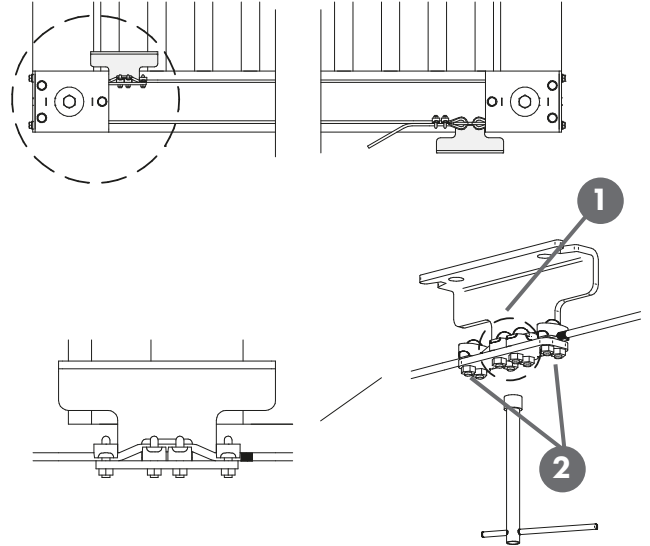

Apriete en la secuencia correcta
Tighten in the correct sequence

7

S1

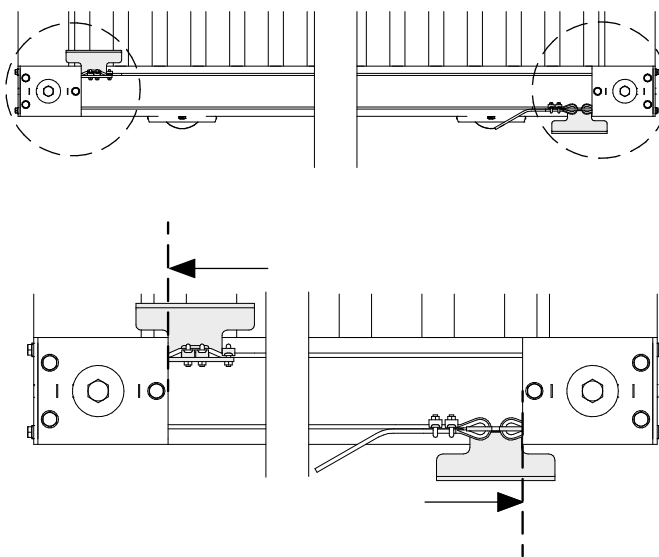

8

S1

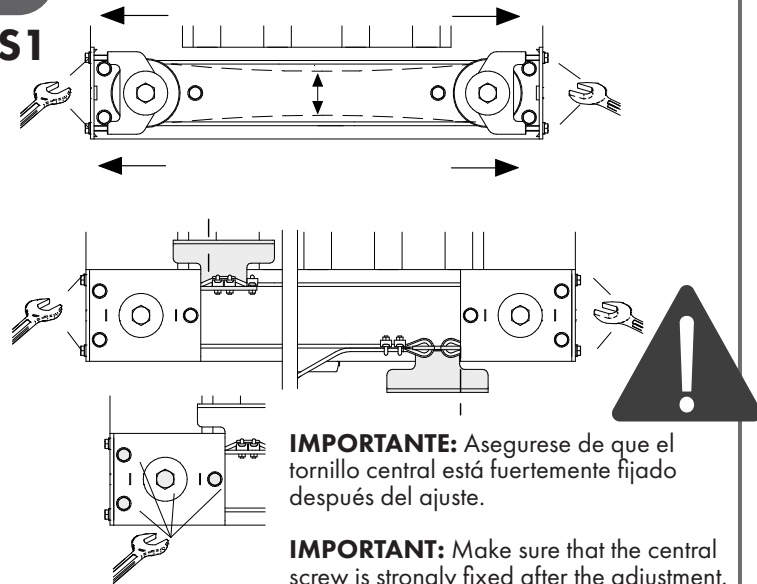

9

S1

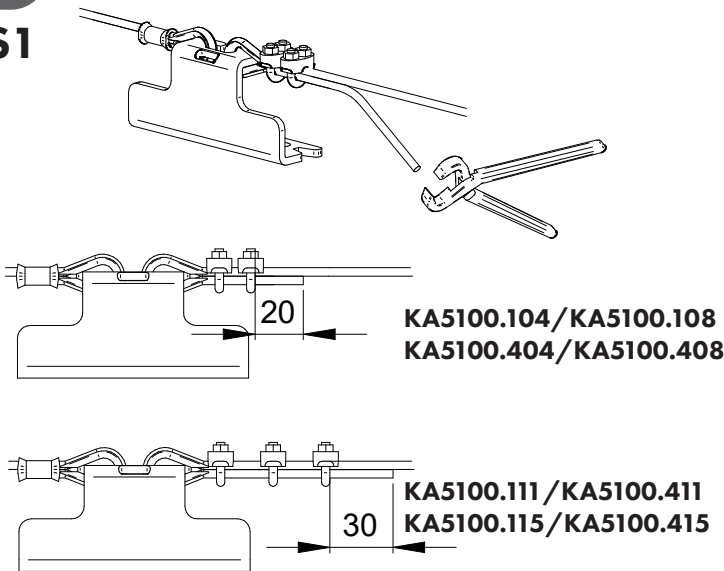

10

S1

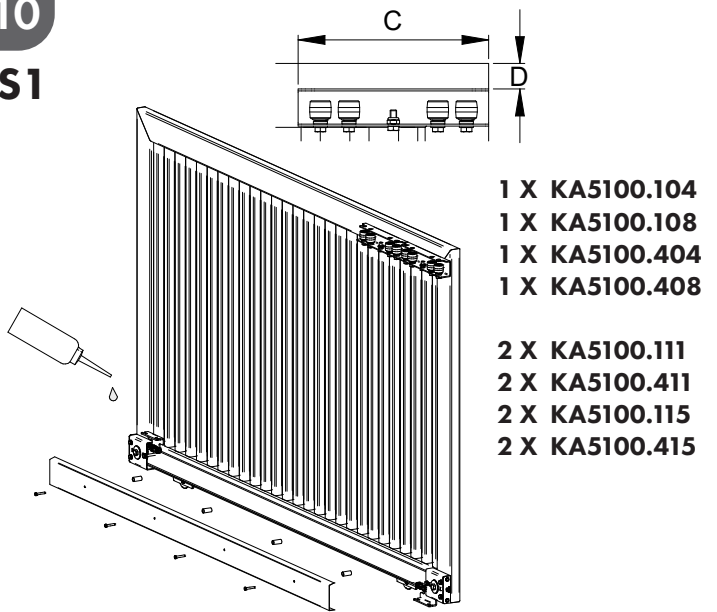

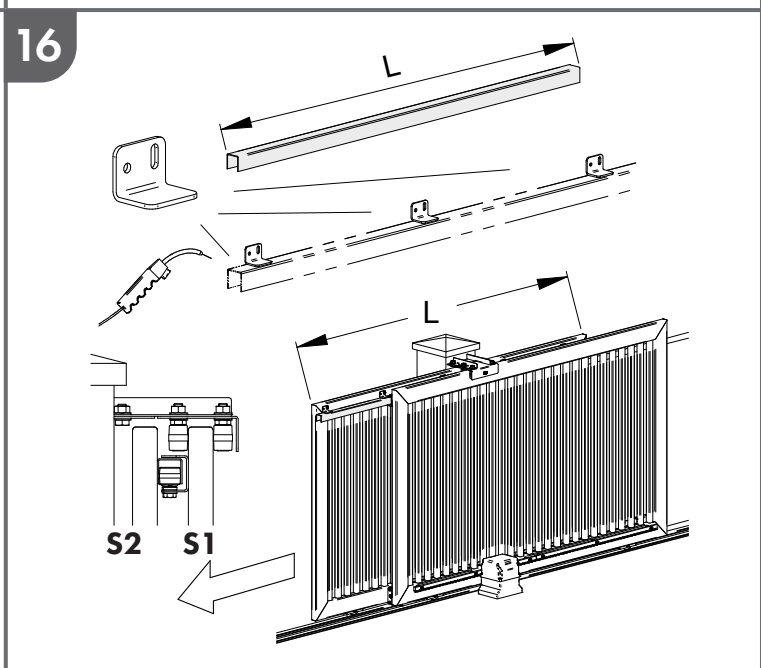
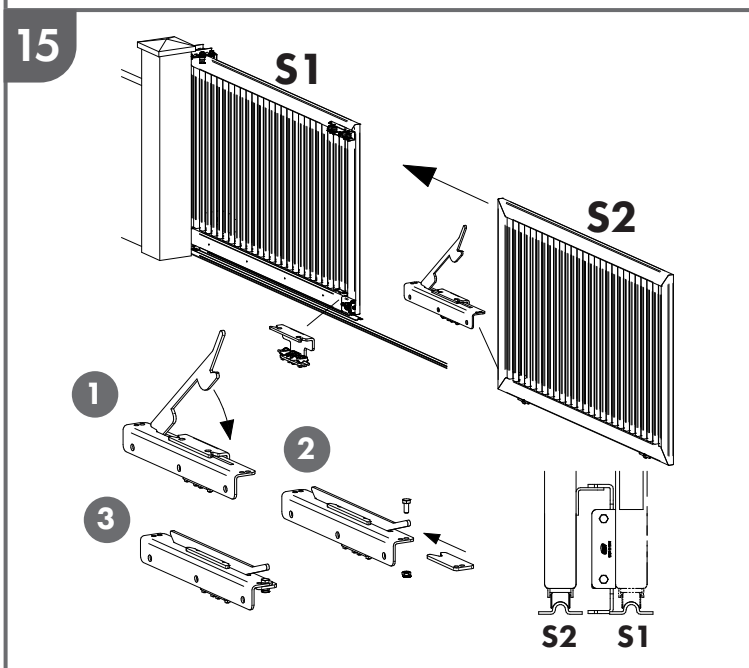
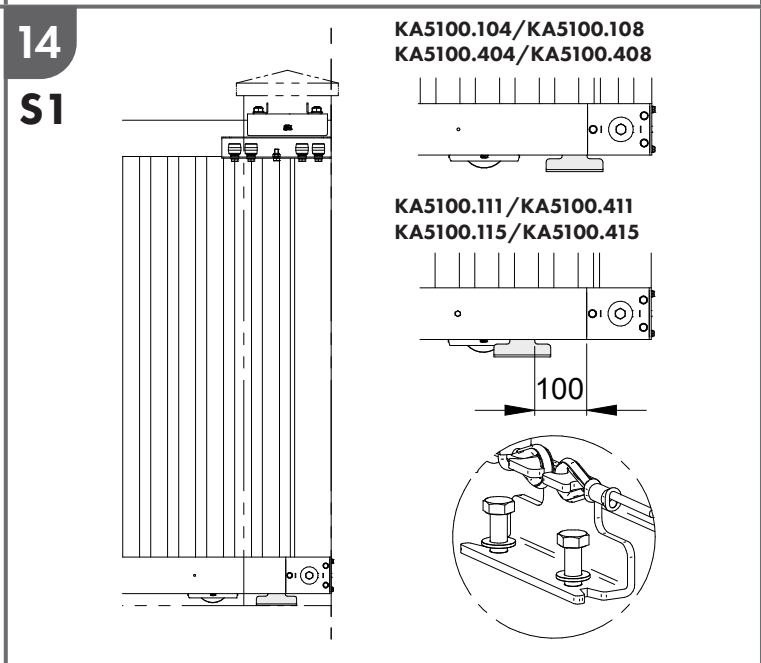
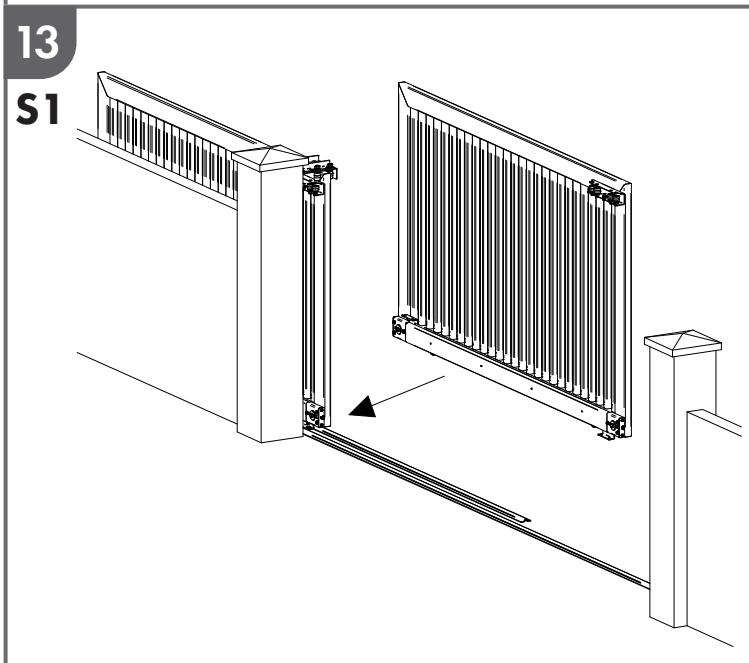
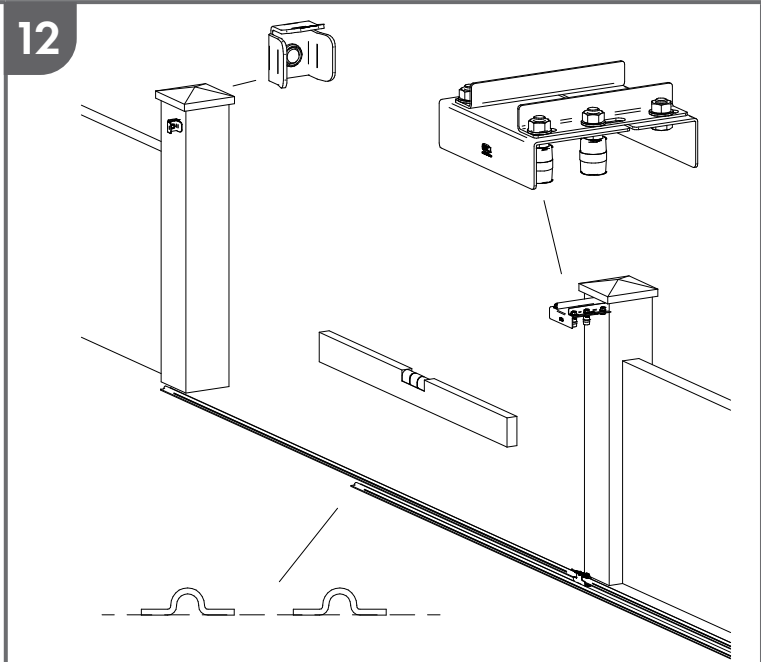
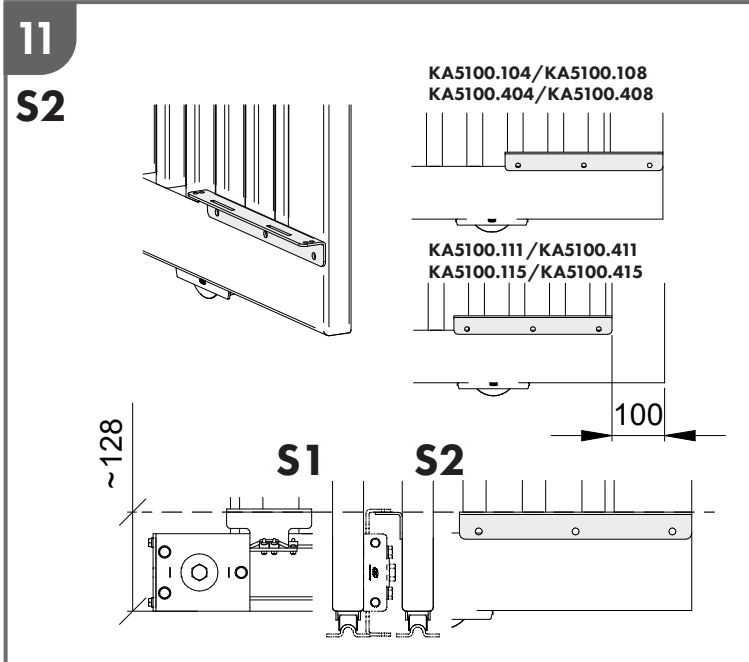

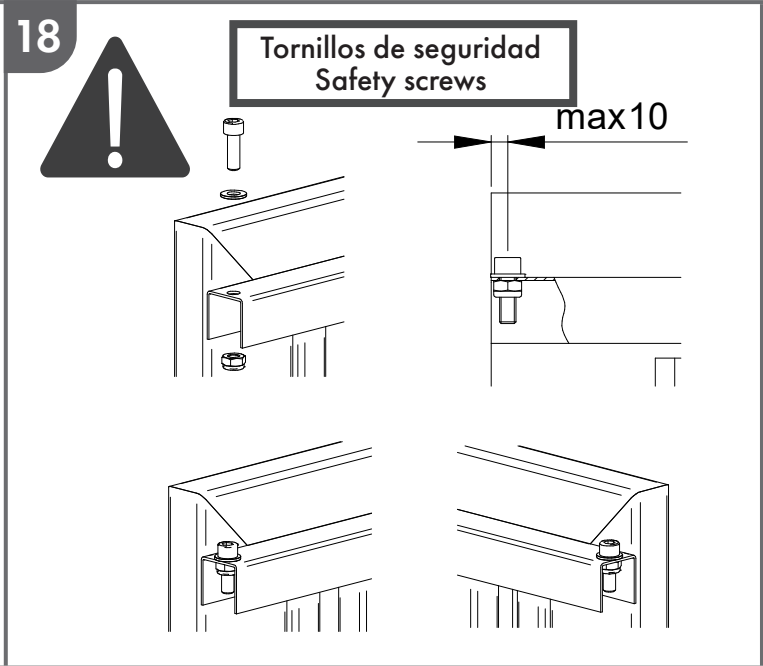
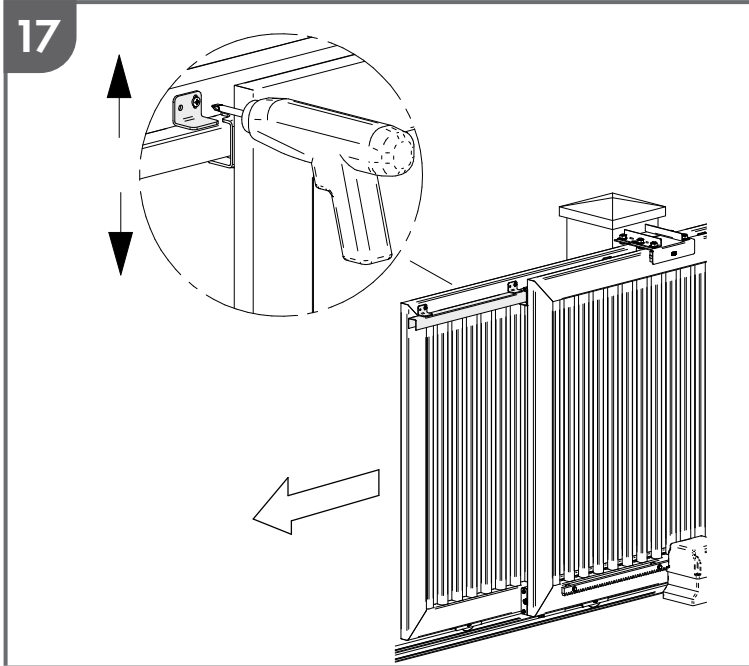

**MANTENIMIENTO
MAINTENANCE**

1. Inspeccione manualmente el funcionamiento al final de la instalación; periódicamente revise que el sistema funciona correctamente, que está bien lubricado que no hay ningún aflojamiento (sugerimos una revisión completa cada 3 meses o después de 8000 ciclos).
2. En caso de funcionamiento incorrecto debido al desgaste o a impactos accidentales, asegúrese que todos los componentes están aptos para soportar la puerta y que su conservación está intacta. Si fuera necesario, proceda con la sustitución.
3. FAC asegura el correcto funcionamiento del sistema solo si se usan componentes originales.

Atención: El Kit incluye accesorios y la propuesta de instalación hace referencia a un ejemplo estándar. Una instalación que no esté de acuerdo con el procedimiento ilustrado y la omisión del correcto mantenimiento podrían comprometer bienes cercanos y la seguridad de las personas. Asegúrese de que todos los accesorios se adaptan a su trabajo específico y asegúrese del uso de los dispositivos de seguridad previstos por las regulaciones vigentes.

Para más información: info@facsl.com

1. Perform all functioning inspections manually at the end of the installation; periodically check that the system is functioning, that it is well lubricated and does not have any loosening (we suggest a full examination every 3 months or after 8000 cycles).
2. In case of malfunctions due to wear or accidental impacts, make sure that all components apt to support the gate and its maintenance are intact. If necessary, proceed with substitution.
3. FAC ensures the system correct functioning only using original spare parts.

Attention: The kit included accessories and the proposed installation make reference to a standard example. An installation not in accordance with the illustrated procedure and the omission of the correct maintenance might compromise nearby things and people's security. Make sure that all accessories suit the specific work and make sure to use the necessary safety devices provided by current regulations.

For more information: info@facsl.com